

# 6.200 Midterm

Fall 2024

Name:

Kerberos/Athena Username:

5 questions

2 hours

- Please **WAIT** until we tell you to begin.
- Write your name and kerberos **ONLY** on the front page.
- This exam is closed-book, but you may use one 8.5" × 11" sheet of handwritten notes (both sides) as a reference. This sheet must be **handwritten** directly on the page (not printed).
- You may **NOT** use any electronic devices (including computers, calculators, phones, etc.).
- If you have questions, please **come to us at the front** to ask them.
- Enter all answers in the boxes provided. Work on other pages with QR codes may be taken into account when assigning partial credit provided you indicate (near the answer box) where that work can be found.
- You may remove sheets from the exam if you wish, but we must receive **all** sheets with QR codes back from you at the end of the exam.
- **Please do not write on the QR codes.**
- If you finish the exam more than 10 minutes before the end time, please quietly bring your exam to us at the front of the room. If you finish within 10 minutes of the end time, please remain seated so as not to disturb those who are still finishing their exams.
- You may not discuss the details of the exam with anyone other than course staff until final exam grades have been assigned and released.

*Worksheet (intentionally blank)*

*Worksheet (intentionally blank)*

# 1 Sorcery

Consider the following three circuits, which are all slight variants of each other. The resistors are configured the same way in all three circuits; the only difference between them is the sources.

## Variation 1 (Current Source)

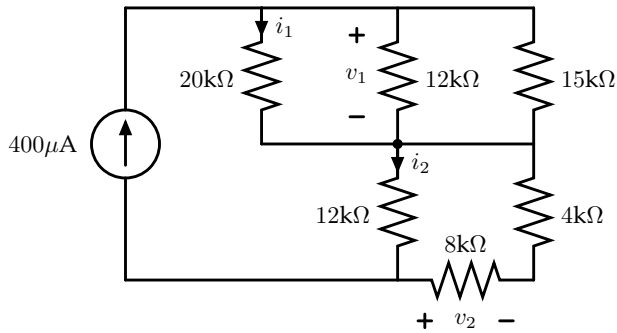

## Variation 2 (Voltage Source)

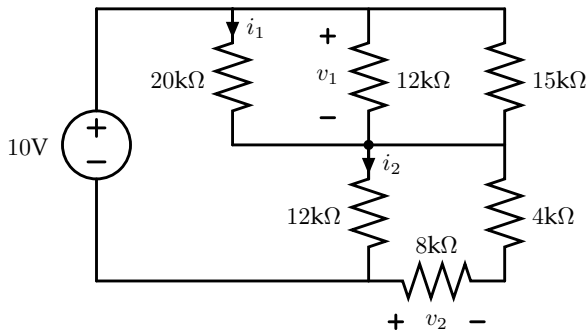

## Variation 3 (Both Sources)

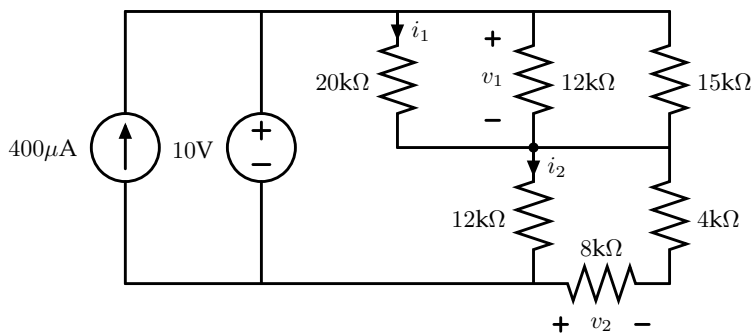

Answer the questions about these circuits on the facing page. Each of your answers should be a single number (or simplified fraction), with appropriate units.

**1.1 Variant 1**

Solve for the following values (including units) in variant 1 (with only the current source connected):

$$v_1 = \boxed{\phantom{000000}} \quad v_2 = \boxed{\phantom{000000}} \quad i_1 = \boxed{\phantom{000000}} \quad i_2 = \boxed{\phantom{000000}}$$

**1.2 Variant 2**

Solve for the following values (including units) in variant 2 (with only the voltage source connected):

$$v_1 = \boxed{\phantom{000000}} \quad v_2 = \boxed{\phantom{000000}} \quad i_1 = \boxed{\phantom{000000}} \quad i_2 = \boxed{\phantom{000000}}$$

**1.3 Variant 3**

Finally, solve for the following values (including units) in variant 3 (with both sources connected):

$$v_1 = \boxed{\phantom{000000}} \quad v_2 = \boxed{\phantom{000000}} \quad i_1 = \boxed{\phantom{000000}} \quad i_2 = \boxed{\phantom{000000}}$$

## 2 Time Dynamics

For each of the two circuits that follow, sketch the indicated values as functions of time on the facing pages.

### 2.1 Part 1

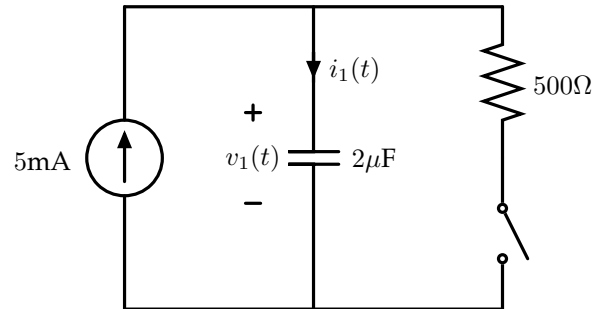

The switch is closed for all time  $t < 0$ , such that by time 0 it is operating in a steady state.

At time  $t = 0$ , the switch opens and remains open for 3ms.

At time  $t = 3\text{ms}$ , the switch closes again and remains closed forever.

On the axes on the facing page, sketch  $v_1(t)$  and  $i_1(t)$  as functions of  $t$ , labeling all key values, slopes, asymptotes, and time constants.

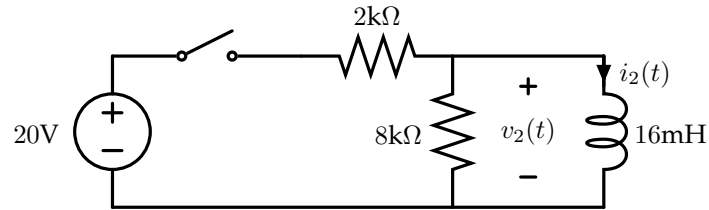

**2.2 Part 2**

Before time 0, the switch is open and  $i_2(0_-) = 0$ .

The switch is then closed from  $0 \leq t < 50\mu s$ .

At  $t = 50\mu s$ , the switch is opened again, and it remains open forever.

On the axes on the facing page, sketch  $v_2(t)$  and  $i_2(t)$  as functions of  $t$ , labeling all key values, slopes, asymptotes, and time constants.





*Worksheet (intentionally blank)*

### 3 Potentiometers

Problems from problem sets 2 and 4 explored using potentiometers as variable voltage dividers. In this problem, we'll explore using a potentiometer in a different way, as a current divider instead. We've drawn our starting circuit two different ways below, one that shows the potentiometer as a single device, and one that shows both individual resistors inside of the potentiometer (recall that  $\alpha$  is a number in the range  $0 \leq \alpha \leq 1$  that indicates how far the potentiometer has been turned):

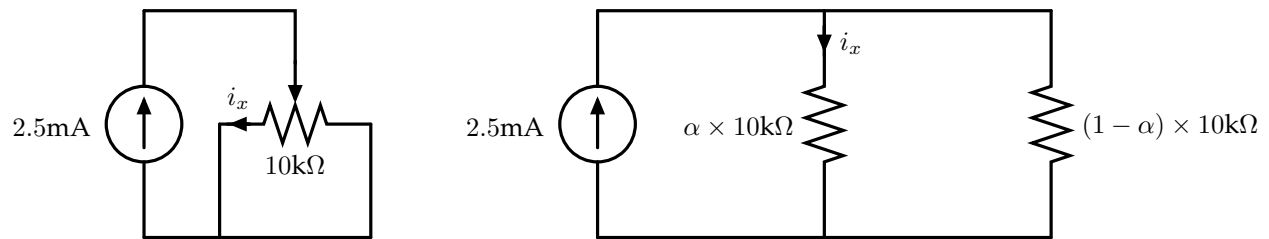

As in those problem set questions, here we'll look at how a variable within the circuit changes as we turn the potentiometer (i.e., as  $\alpha$  changes).

In the configuration shown above, the relationship between  $\alpha$  and  $i_x$  is indicated on the following graph:

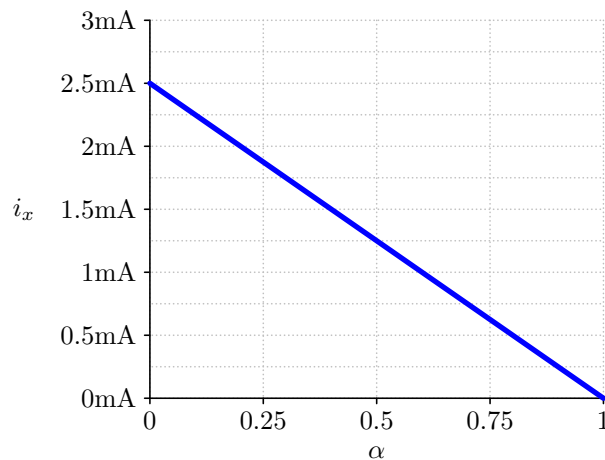

The following two pages show three variants of this circuit, each with an additional resistor added. For each variant, the value of  $R$  may be  $1\Omega$ , or  $1k\Omega$ , or  $1M\Omega$ .

Additionally, the last page of this exam (page 27, which you may remove from this handout) contains several graphs of functions relating  $\alpha$  and  $i_x$ . For each variant and resistance value, indicate which of the graphs best represents the relationship from that circuit. If the resulting graph would be indistinguishable from that of the original circuit, write **same** in the box instead.

### 3.1 Variant 1

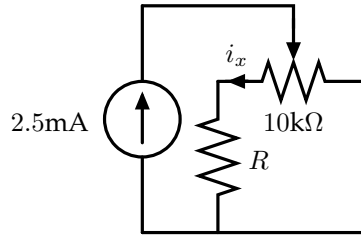

When  $R = 1\Omega$ , what graph shows the relationship between  $i_x$  and  $\alpha$ ?

When  $R = 1\text{k}\Omega$ , what graph shows the relationship between  $i_x$  and  $\alpha$ ?

When  $R = 1\text{M}\Omega$ , what graph shows the relationship between  $i_x$  and  $\alpha$ ?

### 3.2 Variant 2

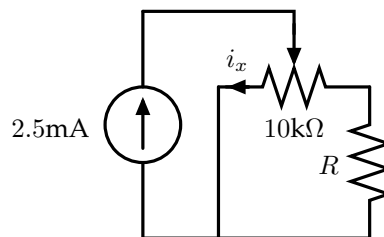

When  $R = 1\Omega$ , what graph shows the relationship between  $i_x$  and  $\alpha$ ?

When  $R = 1\text{k}\Omega$ , what graph shows the relationship between  $i_x$  and  $\alpha$ ?

When  $R = 1\text{M}\Omega$ , what graph shows the relationship between  $i_x$  and  $\alpha$ ?

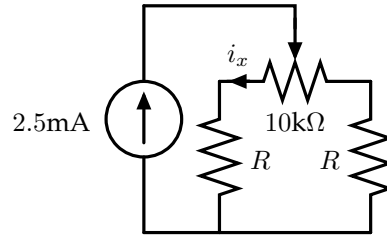
**3.3 Variant 3**

When  $R = 1\Omega$ , what graph shows the relationship between  $i_x$  and  $\alpha$ ?

When  $R = 1\text{k}\Omega$ , what graph shows the relationship between  $i_x$  and  $\alpha$ ?

When  $R = 1\text{M}\Omega$ , what graph shows the relationship between  $i_x$  and  $\alpha$ ?

## 4 Dependent Sources

### 4.1 Circuit 1

Consider the circuit below:

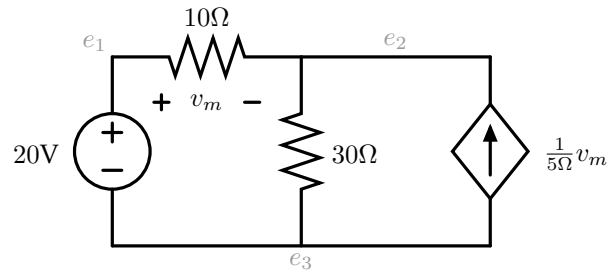

Choose one of the labeled nodes to be your 0V reference point and solve for the other node potentials relative to that potential. Enter your answers (including units) in the boxes below:

$e_1 =$

$e_2 =$

$e_3 =$

*Worksheet (intentionally blank)*

## 4.2 Circuit 2

Now consider the circuit below:

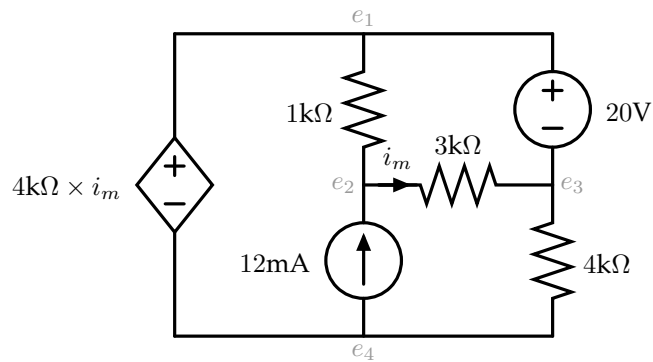

Choose one of the labeled nodes to be your 0V reference point and solve for the other node potentials relative to that potential. Enter your answers (including units) in the boxes below:

$$e_1 =$$

$$e_2 =$$

$$e_3 =$$

$$e_4 =$$



*Worksheet (intentionally blank)*

## 5 Trick-or-Circuit

After a night of trick-or-treating, you discover that your neighbor has given you what looks like a fun-size Snickers candy bar. But the presence of two metal terminals on it make you suspect that they may be playing a prank on you, giving you what looks like a Snickers bar but is actually a circuit consisting of only linear components (classic!). To test your theory, you connect two wires to those terminals, like so:

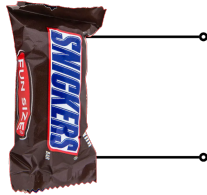

You feel vindicated in your earlier assessment when you make the following measurements after hooking up some additional components to the prank “candy bar;” there’s clearly more in there than just nougat, caramel, peanuts, and milk chocolate!

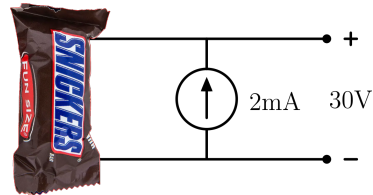
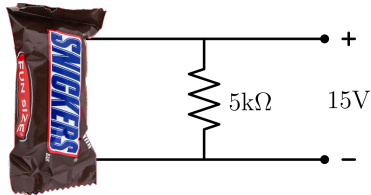

You decide to investigate a little further. For each of the connections on the facing page, indicate what voltage would be measured so as to be consistent with your measurements from above.

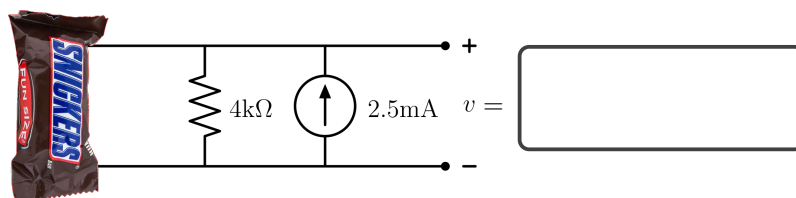
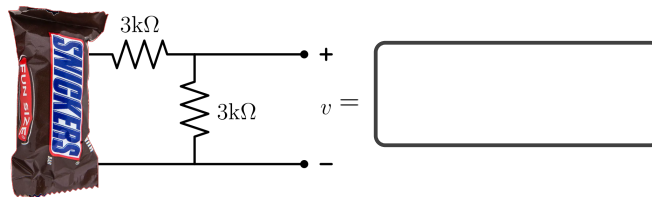
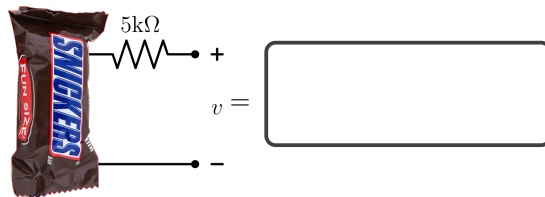
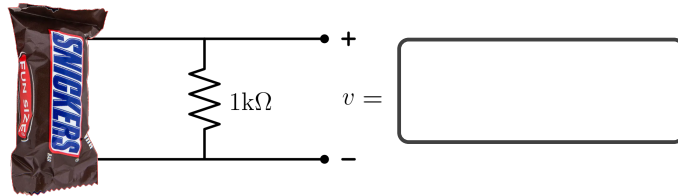

*Worksheet (intentionally blank)*

*Worksheet (intentionally blank)*

*Worksheet (intentionally blank)*

*Worksheet (intentionally blank)*

*Worksheet (intentionally blank)*



*Worksheet (intentionally blank)*

*Worksheet (intentionally blank)*

## Graphs for Potentiometer Question

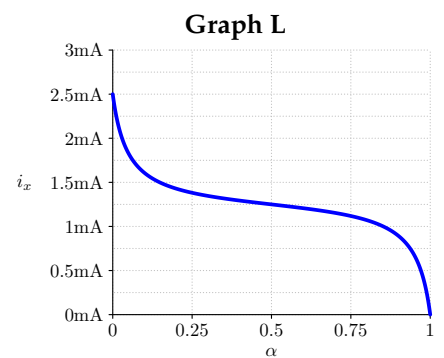
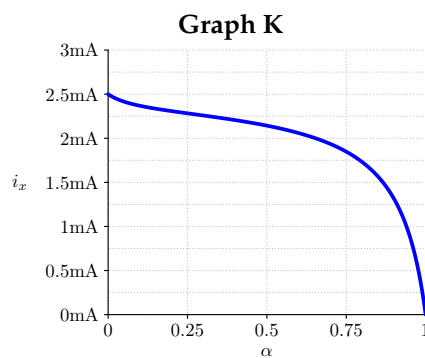
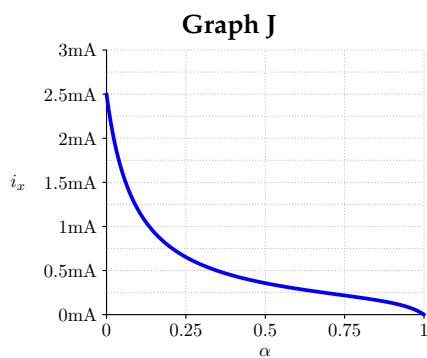
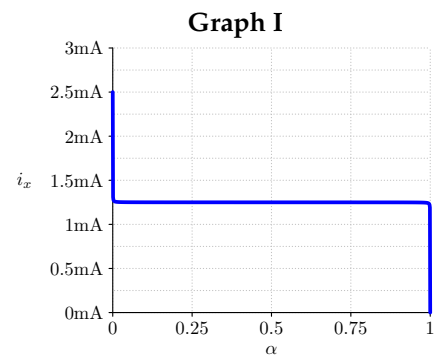
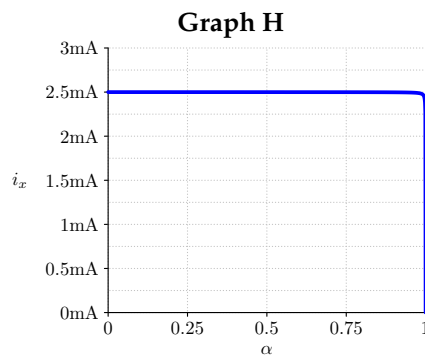
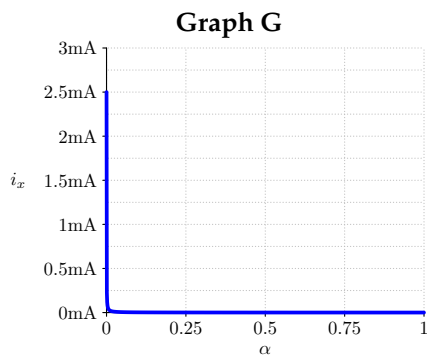
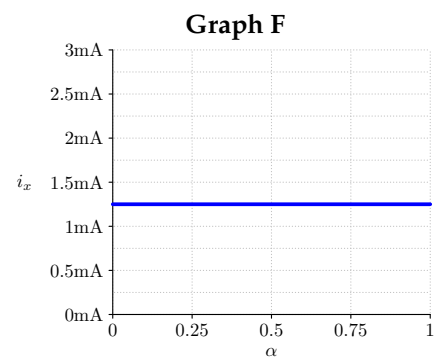
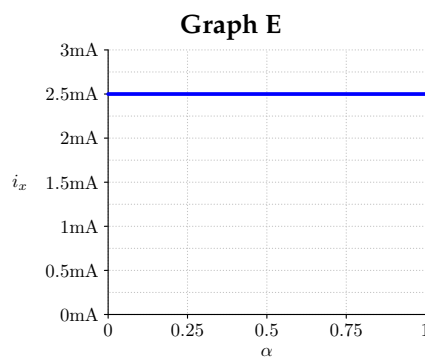
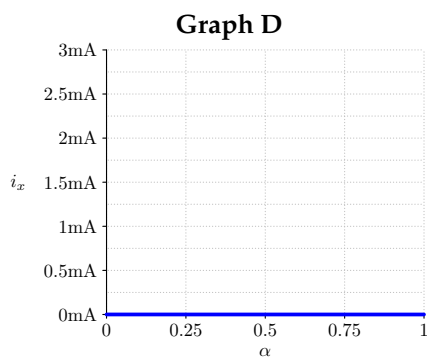
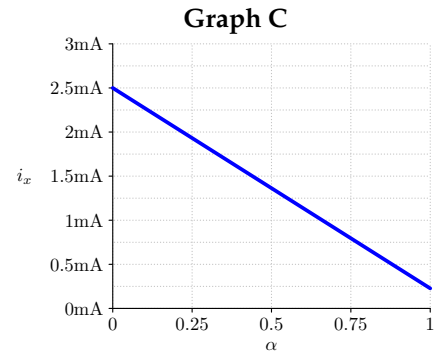
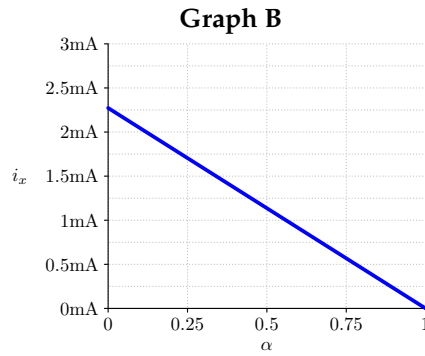
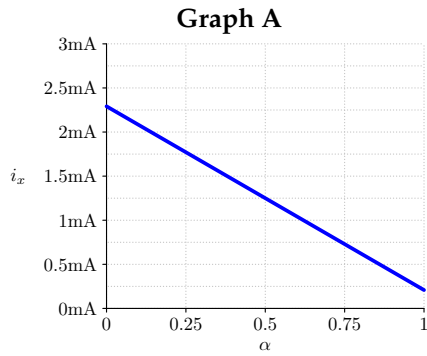

*Worksheet (intentionally blank)*