

6.200 - Lecture 17

Driven RLC Networks

- Second-Order Networks
- Network Equivalence
- Homogeneous Response
- Particular Response
- Total Response

Driven Series RLC Networks

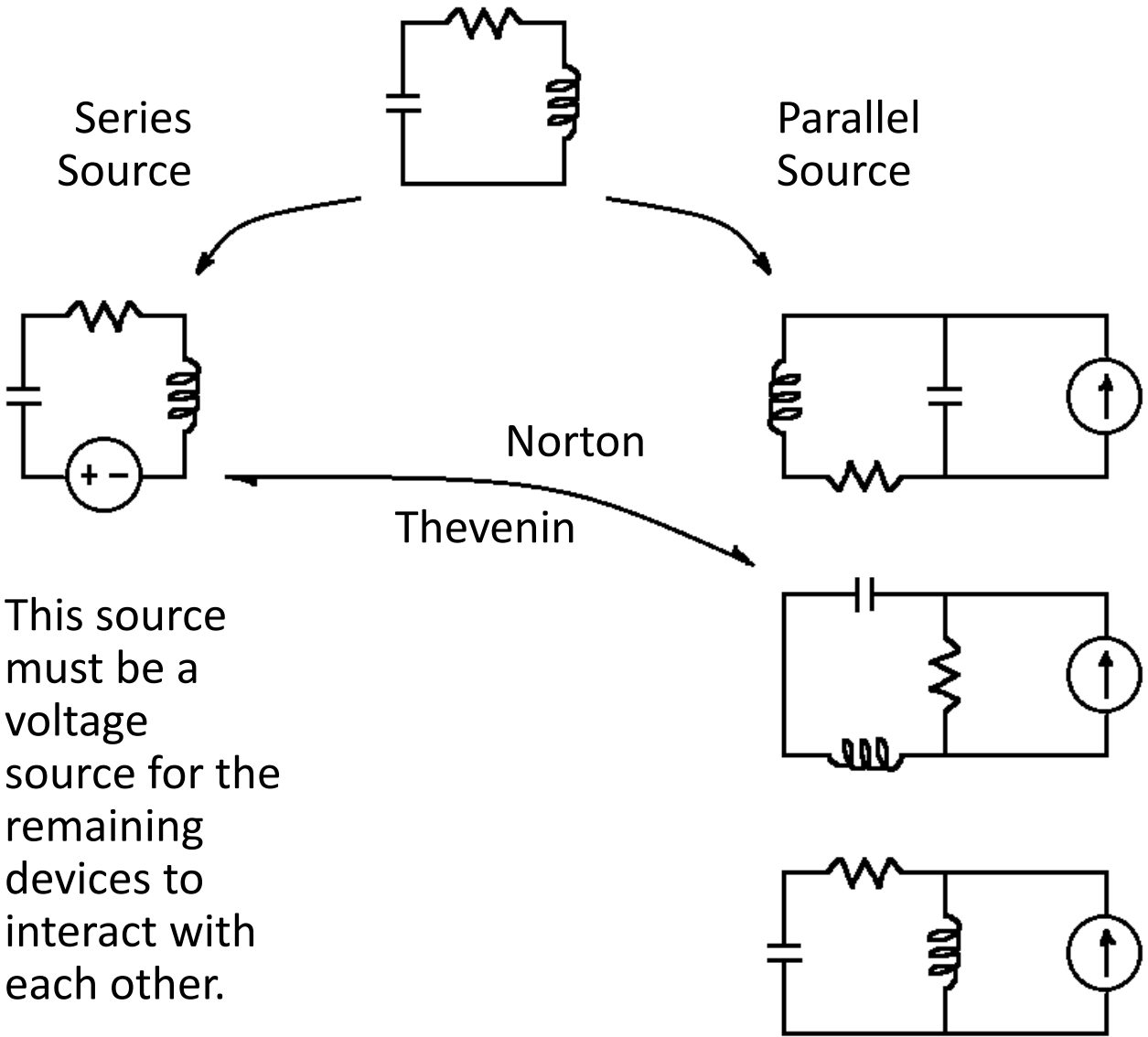

This source must be a voltage source for the remaining devices to interact with each other.

These sources must all be current sources for the remaining devices to interact with each other.

Driven Parallel RLC Networks

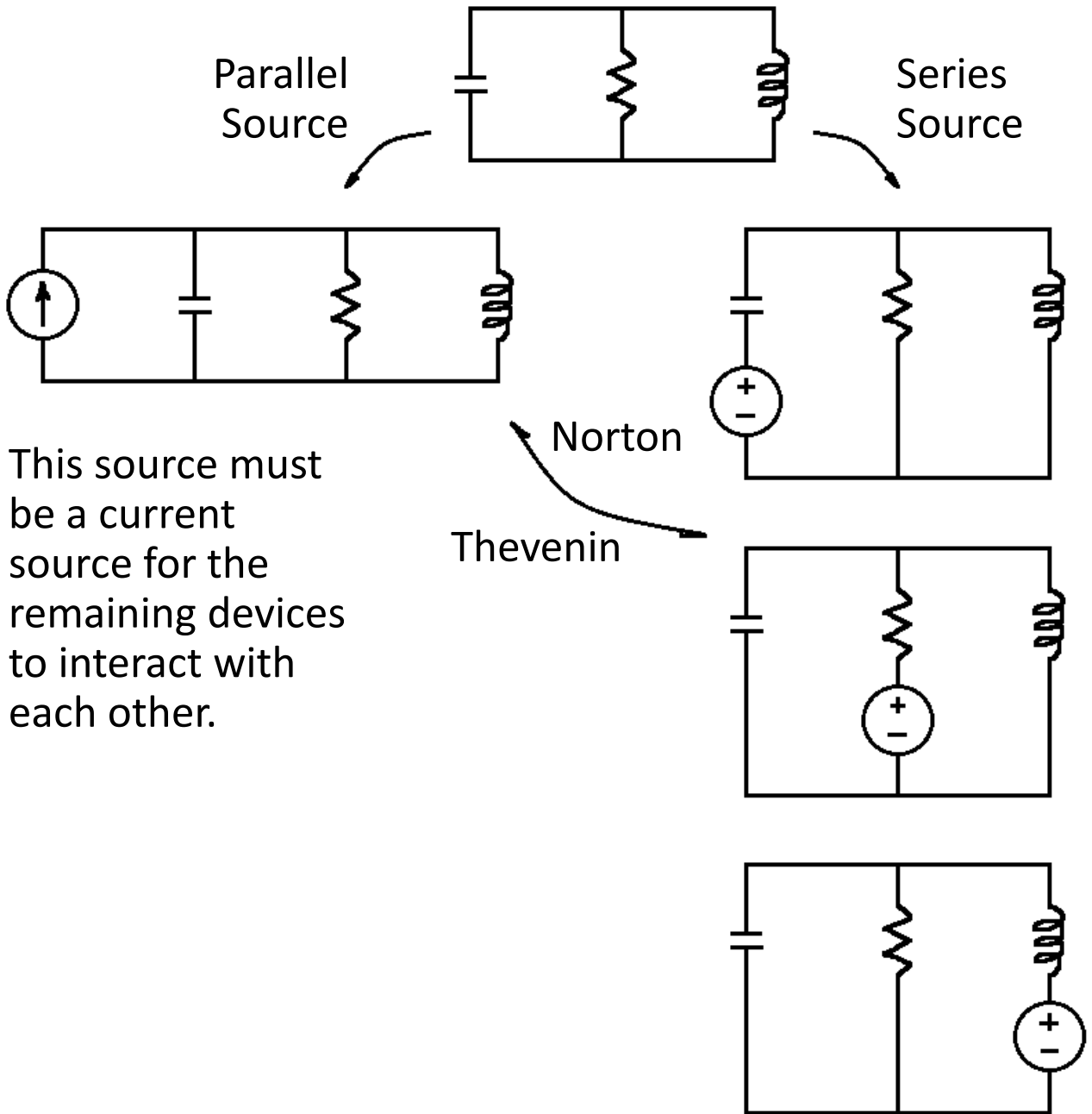

This source must be a current source for the remaining devices to interact with each other.

These sources must all be voltage sources for the remaining devices to interact with each other.

v-i Equivalence

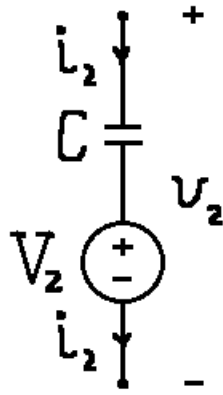
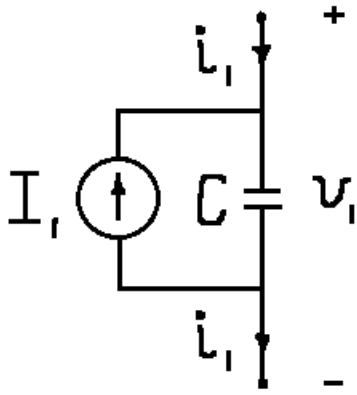

$$i_1 + I_1 = C \frac{d}{dt} v_1$$

$$i_2 = C \frac{d}{dt} (v_2 - V_2)$$

⇓

$$I_1 = C \frac{d}{dt} V_2 \quad t \geq -\infty$$

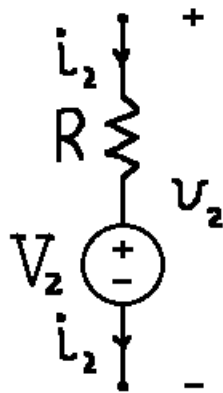
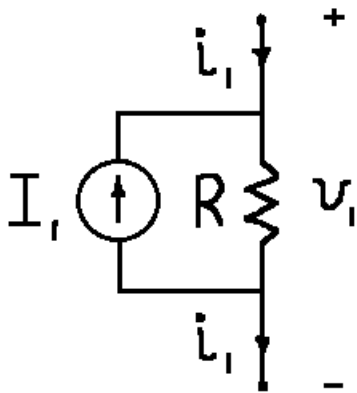

$$v_1 = R(i_1 + I_1)$$

$$v_2 = R i_2 + V_2$$

⇓

$$R I_1 = V_2$$

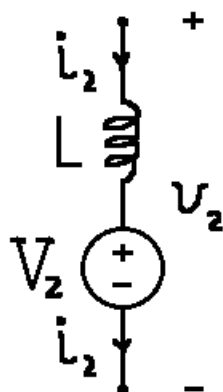
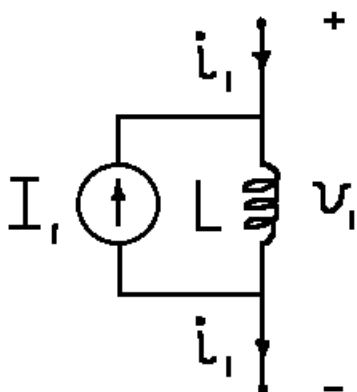

$$v_1 = L \frac{d}{dt} (i_1 + I_1)$$

$$v_2 = L \frac{d}{dt} i_2 + V_2$$

⇓

$$L \frac{d}{dt} I_1 = V_2 \quad t \geq -\infty$$

Equivalence Example

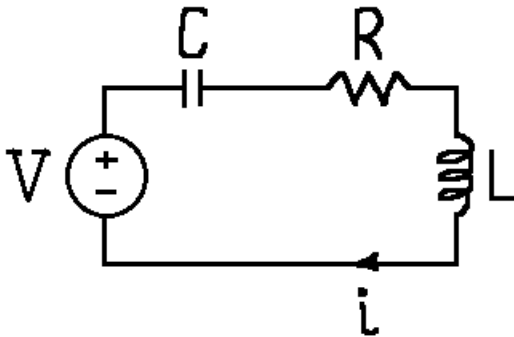

$$V = \frac{1}{C} \int i dt + Ri + L \frac{di}{dt}$$

$$\frac{d^2 i}{dt^2} + \frac{R}{L} \frac{di}{dt} + \frac{i}{LC} = \frac{1}{L} \frac{dV}{dt}$$

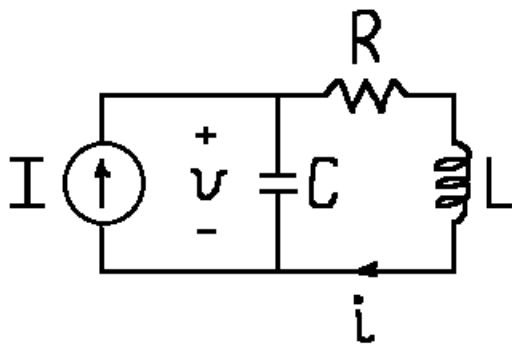

$$v = Ri + L \frac{di}{dt}$$

$$v = \frac{1}{C} \int (I - i) dt$$

$$\frac{d^2 i}{dt^2} + \frac{R}{L} \frac{di}{dt} + \frac{i}{LC} = \frac{I}{LC}$$

The two networks behave identically when $I = C dV/dt$.

All series RLC networks have the same homogeneous/natural response, due to the common network obtained with the sources set to zero. Similarly, all parallel RLC networks have the same homogeneous/natural response. The only difference from network to network within each set is the nature of the drive.

Homogeneous Response

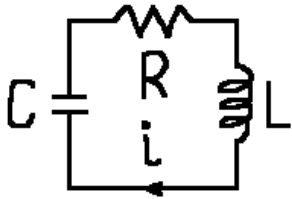

KVL \Rightarrow

$$\frac{1}{C} \int i dt + Ri + L \frac{di}{dt} = 0$$

$$\frac{d^2 i}{dt^2} + \frac{R}{L} \frac{di}{dt} + \frac{i}{LC} = 0$$

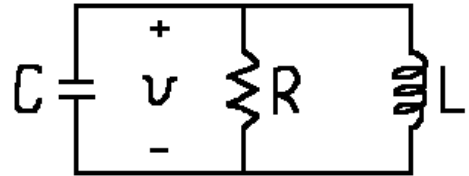

KCL \Rightarrow

$$\frac{1}{L} \int v dt + \frac{v}{R} + C \frac{dv}{dt} = 0$$

$$\frac{d^2 v}{dt^2} + \frac{1}{RC} \frac{dv}{dt} + \frac{v}{LC} = 0$$

Common Form: $d^2 x / dt^2 + 2\alpha dx / dt + \omega_0^2 x = 0$

α = Decay Rate

Q = Quality Factor

S = Damping Factor

ω_0 = Undamped Natural Frequency

$$\omega_0 / Q$$
$$2S\omega_0$$

Common Response: e^{st} , $s = -\alpha \pm j\sqrt{\omega_0^2 - \alpha^2} = -\alpha \pm j\omega_d$

$\Rightarrow e^{-\alpha t} \sin(\omega_d t)$ & $e^{-\alpha t} \cos(\omega_d t)$

ω_d = Damped Natural Frequency

Analysis: Series RLC Network

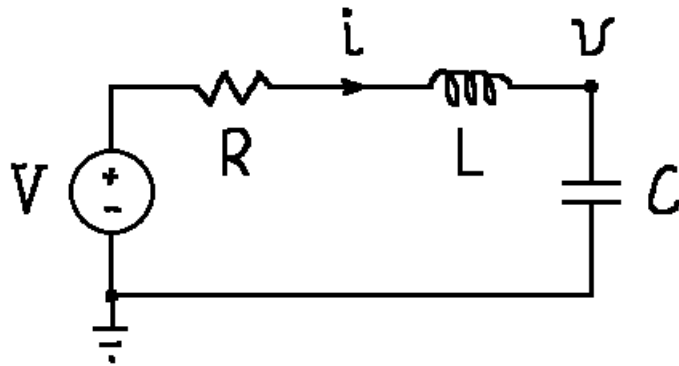

$$\text{KVL} \Rightarrow \frac{1}{C} \int i dt + Ri + L \frac{di}{dt} = V$$

$$i = C \frac{dv}{dt}$$

$$\frac{d^2 v}{dt^2} + \frac{R}{L} \frac{dv}{dt} + \frac{v}{LC} = \frac{V}{LC}$$

Note: $\alpha = R/2L$ and $\omega_0 = 1/\sqrt{LC}$

$$v(t) = v_{\text{Particular}} + e^{-\alpha t} (A_s \sin(\omega_d t) + A_c \cos(\omega_d t))$$

where $v_{\text{Particular}}$ is chosen to match V .

Step Response

Let $V = V_0$ with

$$v(0) = 0 \text{ and } i(0) = C dv/dt(0) = 0$$

A good choice for v_p is $v_p = V_0$ so that

$$v(t) = V_0 + e^{-\alpha t} (A_s \sin(\omega_d t) + A_c \cos(\omega_d t))$$

$v(0) = 0 \Rightarrow A_c = -V_0$ so that

$$v(t) = V_0 + e^{-\alpha t} (A_s \sin(\omega_d t) - V_0 \cos(\omega_d t))$$

$$i(t) = -C\alpha e^{-\alpha t} (A_s \sin(\omega_d t) - V_0 \cos(\omega_d t)) \\ + C\omega_d e^{-\alpha t} (A_s \cos(\omega_d t) + V_0 \sin(\omega_d t))$$

$i(0) = 0 \Rightarrow A_s = -(\alpha/\omega_d)V_0$ so that

$$v(t) = V_0 - V_0 e^{-\alpha t} ((\alpha/\omega_d) \sin(\omega_d t) + \cos(\omega_d t))$$

$$i(t) = \alpha C V_0 e^{-\alpha t} ((\alpha/\omega_d) \sin(\omega_d t) + \cos(\omega_d t)) \\ - \omega_d C V_0 e^{-\alpha t} ((\alpha/\omega_d) \cos(\omega_d t) - \sin(\omega_d t)) \\ = (\omega_0^2/\omega_d) C V_0 e^{-\alpha t} \sin(\omega_d t)$$

Step Response

$R = 6.03 \Omega$; $L = 0.1 \text{ H}$; $C = 1.07 \mu\text{F}$; $V = 2 \text{ V}$
 $T = 2.2 \text{ ms}$; $Q = 50.7$

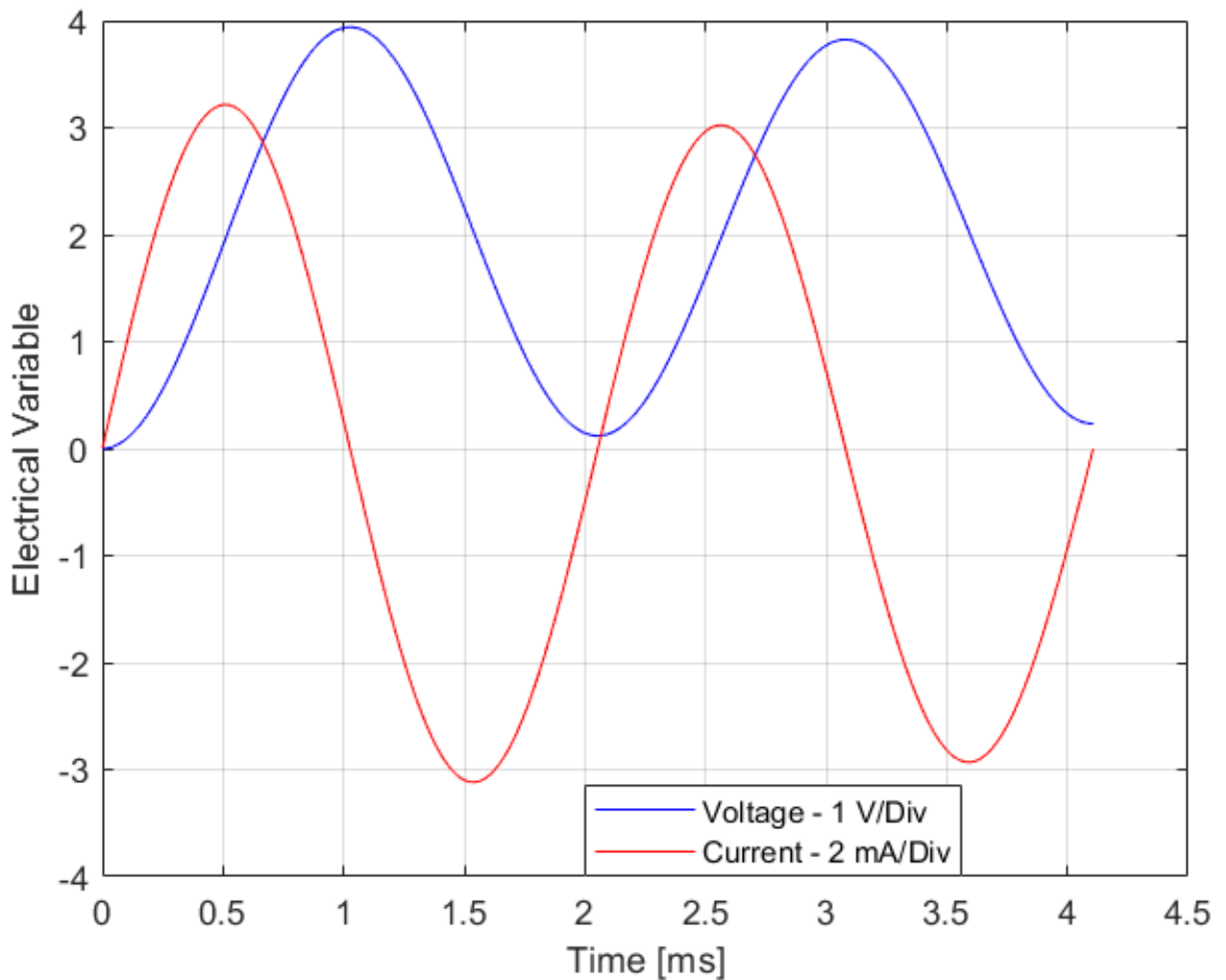

$Q = 50.7 \rightarrow \sim 25$ cycles to reach 20% amplitude

Impulse Response

The impulse response is the natural, or homogeneous, response driven by initial conditions set up by the impulse. To determine the initial conditions, integrate the differential equations across the impulse.

Let $V = \Lambda \delta(t)$ with

$$v(0^-) = 0 \text{ and } i(0^-) = C dv/dt(0^-) = 0$$

$$\int_{0^-}^{0^+} (d^2v/dt^2 + 2\alpha dv/dt + \omega_0^2 v = \omega_0^2 \Lambda \delta(t)) dt \rightarrow$$
$$dv/dt(0^+) - \underbrace{dv/dt(0^-)}_{\text{ZERO}} + 2\alpha(v(0^+) - \underbrace{v(0^-)}_{\text{ZERO}}) = \omega_0^2 \Lambda$$

$$\int_{0^-}^{0^+} (C dv/dt = i) dt \rightarrow v(0^+) - \underbrace{v(0^-)}_{\text{ZERO}} = 0$$

Therefore $v(0^+) = 0$ and $dv/dt(0^+) = \omega_0^2 \Lambda$

so that $v(t) = (\omega_0^2 \Lambda / \omega_d) e^{-\alpha t} \sin(\omega_d t)$ and

$$i(t) = (\Lambda / L) e^{-\alpha t} (\cos(\omega_d t) - (\alpha / \omega_d) \sin(\omega_d t))$$

The voltage impulse falls entirely across the inductor causing i to step to Λ / L .

Impulse Response

$R = 6.03 \Omega$; $L = 0.1 \text{ H}$; $C = 1.07 \mu\text{F}$; $\Lambda = 0.5 \text{ mVs}$

